

MEASUREMENT SYSTEM FOR NONINVASIVE DYNAMIC OPTICAL TOPOGRAPHY

Yuichi Yamashita, Atsushi Maki, and Hideaki Koizumi

Hitachi Ltd., Central Research Laboratory, Kokubunji, Tokyo 185-8601, Japan

(Paper JBO 109906 received Feb. 18, 1999; revised manuscript received June 29, 1999; accepted for publication July 20, 1999.)

ABSTRACT

We have developed a 24-channel simultaneous measurement system for optical topography that noninvasively obtains dynamic images of brain activity using near-infrared light. To evaluate the system performance, we utilized a dynamic phantom containing a rotating absorber in a cylindrical scattering medium. In this system, eight incident and eight detecting optical fibers are arranged alternately at square lattice points on the phantom. The phantom is illuminated with light of two wavelengths (780 and 830 nm) from each incident fiber. Reflected light is received by the detecting fibers, each of which is connected to an avalanche photodiode. Multiple light intensity modulation and lock-in detection are used to enable highly sensitive measurement with negligible cross talk for multichannel measurement. In the phantom measurement, we obtained topographic dynamic images of the absorber rotating in the medium with a temporal resolution of 0.5 s over a measurement area of 90 mm×90 mm. © 1999 Society of Photo-Optical Instrumentation Engineers. [S1083-3668(99)01004-7]

Keywords optical topography; dynamic images; dynamic phantom; lock-in detection.

1 INTRODUCTION

Near-infrared spectroscopy (NIRS) is a useful method to measure noninvasively brain activity¹⁻⁴ by detecting changes in the concentration of oxy and deoxy hemoglobin. More recently, we developed a multichannel NIRS system⁵ and obtained topographic images of brain activity.^{6,7} We call this optical topography, and it provides a new method for noninvasive imaging of brain activity. Optical topography can focus on the cerebral cortex just beneath the skull. The cerebral cortex is the functional tissue related to the higher-order brain activity such as motor control, language, and memory. Furthermore, the cerebral cortex is the 2–5-mm-thick surface layer (gray matter) of the cerebrum and contains dense neurons and blood vessels. The layer of gray matter absorbs the light owing to the hemoglobin in the blood vessels rather than white matter underneath.

For the measurement of brain activity, optical topography has several advantages compared with other methods such as functional magnetic resonance imaging (fMRI), positron emission tomography (PET), and magnetoencephalography (MEG). The main advantages are notably its portability (no special examination room is needed), decreased sensitivity to subject movement, and the potential for real-time measurement.

Our previous optical topography instrument⁵ obtained spatial information by sequentially switching channels, with a mean switching time of about 0.5 s per channel. This yielded a scanning time of 12 s for a 24-channel measurement. The switching system also leads to the constraint that to increase the number of channels would require a longer scanning time. Thus, the temporal resolution of the instrument required improvement, although the system could measure brain activity topographically.

In this paper, we describe a simultaneous 24-channel measurement system that provides improved temporal resolution, and is thus suitable for noninvasive dynamic measurement of brain activity. We have evaluated the system performance using a dynamic phantom containing a rotating absorber in a scattering medium.

2 OPTICAL TOPOGRAPHY SYSTEM

A block diagram of the optical topography system is shown in Figure 1. The system uses 16 0.5 mW laser diodes (eight for wavelengths of 780 nm, and eight for 830 nm). Their intensities are modulated sinusoidally at frequencies ranging from 1.0 to 8.7 kHz. The modulation frequencies are chosen to avoid any overlap in their harmonic frequencies. The 780 nm light is coupled with the 830 nm light by eight optical-fiber couplers, which are then connected to an incident optical fiber (1 mm diameter). In the system, we simultaneously illuminated the

This paper is a revision of a paper presented at the First International Symposium on Medical Near-Infrared Spectroscopy, September 1998, Tokyo, Japan.

Address all correspondence to Yuichi Yamashita. Tel: +81-42-323-1111; Fax +81-42-327-7681; E-mail: yu-yama@crl.hitachi.co.jp

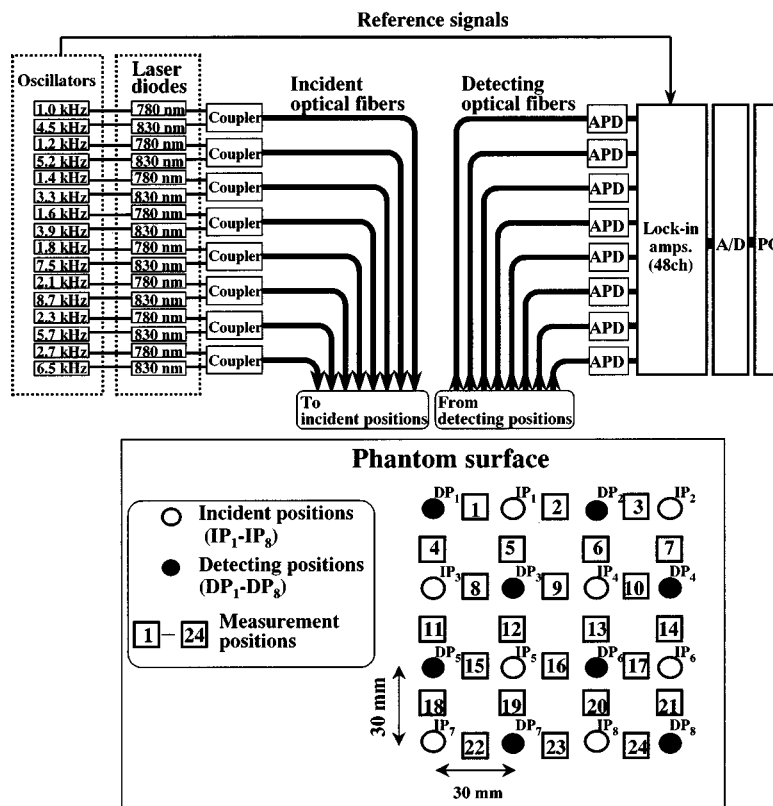

Fig. 1 Block diagram of optical topography system: APD, avalanche photodiode.

phantom with dual wavelength light from the eight incident optical fibers. The light from each laser diode could be uniquely identified by the modulation frequency of the wavelength and the incident position. The reflected light from the phantom was received by eight detecting optical fibers (1 mm diameter) each of which was connected to an avalanche photodiode (APD, Hamamatsu C5460-01) whose noise equivalent power was $20 \text{ fW} / \sqrt{\text{Hz}}$. Each avalanche photodiode output was separated into each modulated signal, which corresponded to the wavelength and incident position, by lock-in amplifiers. To allow simultaneous measurement, we use 48 lock-in amplifiers in this system for 24 measurement channels and two wavelengths. Each lock-in amplifier included a phase-sensitive detector (NF Corporation CD-505R2) integrated circuit (IC) module. The input equivalent noise voltage of the lock-in amplifier was $30 \text{ nV} / \sqrt{\text{Hz}}$. Because the noise voltage of the APD output after the current-to-voltage amplifier was $2 \mu\text{V} / \sqrt{\text{Hz}}$, the sensitivity of the lock-in amplifier was sufficient for the system. Also, the time constant of the lock-in amplifiers was 40 ms (corresponding to a stabilizing time of about 200 ms). The 48 output signals of the lock-in amplifiers were sent to a computer via a multichannel analog-to-digital converter (Keithley MetraByte DAS-1801HC) with a sampling rate of 0.5 s.

Incident and detecting optical fibers were arranged alternately on square lattice points on the phantom (Figure 1). The nearest distance between

the incident and detecting positions was 30 mm, which was the optimal distance for efficiently receiving the light from the cerebral cortex after passing through the skin and the skull.⁸ Thus, the measurement area of this fiber arrangement was $90 \text{ mm} \times 90 \text{ mm}$. The average measurement positions were at the midpoints between the incident and detection positions due to the optical path of the light.⁹

The 24 combinations of neighboring incident and detecting fibers corresponded to 24 measurement positions (that is, 24 measurement channels).

For example, with this configuration, the light detected from position 6 (DP₆) in Figure 1 included input from incident positions 4, 5, 6, and 8 (IP₄, IP₅, IP₆, and IP₈). Since two wavelengths were used at each incident position, eight signals were picked up at position 6. Because these signals each had a different modulation frequency that corresponded to their wavelength and incident positions, the output of the APD connected to detecting position 6 could be separated into eight modulated signals by the eight lock-in amplifiers. Through the modulation and lock-in detection for all detected light, we could obtain highly sensitive simultaneous measurement for optical topography with virtually no cross talk between the signals (less than -50 dB), optical loss (no optical filter or diffraction grating for spectroscopic measurement), or time loss (no switch).

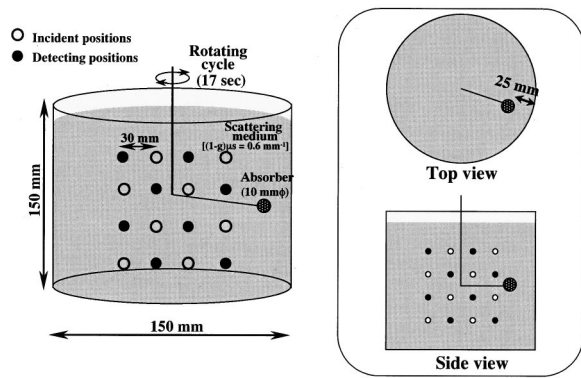

Fig. 2 Arrangement of the phantom.

3 PHANTOM

To estimate the system performance, we used a localized absorber rotating within a scattering medium. Figure 2 shows the arrangement of the phantom. A cylindrical transparent plastic container (diameter of 150 mm and height of 150 mm) was filled with a 10 vol% solution of milk in water to provide a liquid scattering medium. The reduced scattering coefficient $(1-g)\mu_s$ of the medium was 0.6 mm^{-1} , where μ_s is the scattering coefficient and g is the mean cosine of the scattering angle. The value of the reduced scattering coefficient was determined by using a diffusion model,¹⁰ and was almost the same as the reduced scattering coefficients of biological tissues.¹¹

In the scattering medium, a spherical absorber (10 mm diameter) painted matte black was located such that the distance between the center of the absorber and the inner surface of the container was 25 mm, because the cerebral cortex is located at 15–25 mm below the scalp. The absorber was rotated continuously in the medium with a cycle time of 17 s.

We performed this experiment using one wavelength (830 nm) and measured the reflected light intensity.

4 RESULTS AND DISCUSSION

Using the reflected light intensity with the absorber, $I_{\text{abs}}(t)$, at time t and without the absorber I_{nonabs} , we calculated the absorbance change $\Delta A(t)$ for each measurement position with the following equation:

$$\Delta A(t) = -\log_{10} \left(\frac{I_{\text{abs}}(t)}{I_{\text{nonabs}}} \right). \quad (1)$$

By interpolating the absorbance changes between the measurement positions using a third-order spline function, topographic images of the absorber were dynamically obtained. Figure 3 shows images acquired with a temporal resolution of 0.5 s over a measurement area of 90 mm × 90 mm. In this experiment, the absorber crossed the measurement area

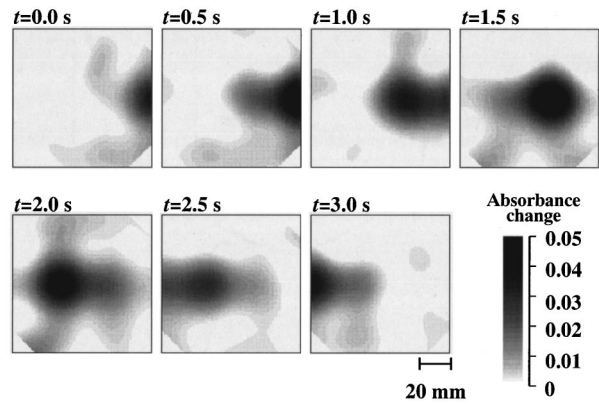

Fig. 3 Topographic dynamic images of the phantom.

from right to left due to the rotation. The spatial resolution of the topographic images is 25 mm, which is the same as the static estimation based on the full width at half maximum of the image profile.⁵

The phantom results demonstrate that optical topography has the potential to become an effective method for detecting not only brain activity localization, but also the spatial and temporal connections and cross correlations between the cortical areas. These results also suggest that topography can be used to produce dynamic perfusion maps in optically dense media. In clinical application, dynamic optical topography has already been used, for example, to image dynamic response during epileptic seizures.¹²

5 CONCLUSION

We have developed an optical topography system that can image brain activity through simultaneous 24-channel measurement using near-infrared light. To evaluate the system performance we obtained dynamic topographic images of a phantom with a temporal resolution of 0.5 s from a measurement area of 90 mm × 90 mm. Results suggest that this system can measure subsecond dynamic changes in absorption such as those which accompany functional hemodynamic response or single pass bolus perfusion studies.

REFERENCES

1. T. Kato, A. Kamei, S. Takashima, and T. Ozaki, "Human visual cortical function during photic stimulation monitoring by means of near-infrared spectroscopy," *J. Cereb. Blood Flow Metab.* **13**, 516–520 (1993).
2. B. Chance, Z. Zhuang, C. UnAh, C. Alter, and L. Lipton, "Cognition-activated low-frequency modulation of light absorption in human brain," *Proc. Natl. Acad. Sci. USA* **90**, 3770–3774 (1993).
3. A. Villringer, J. Planck, C. Hock, L. Schlinkofer, and U. Dirnagl, "Near infrared spectroscopy (NIRS): A new tool to study hemodynamic changes during activation of brain function in human adults," *Neurosci. Lett.* **154**, 101–104 (1993).

4. Y. Hoshi and M. Tamura, "Dynamic multichannel near-infrared optical imaging of human brain activity," *J. Appl. Physiol.* **75**, 1842-1846 (1993).
5. Y. Yamashita, A. Maki, and H. Koizumi, "Near-infrared topographic measurement system: Imaging of absorbers localized in a scattering medium," *Rev. Sci. Instrum.* **67**, 730-732 (1996).
6. A. Maki, Y. Yamashita, Y. Ito, E. Watanabe, Y. Mayanagi, and H. Koizumi, "Spatial and temporal analysis of human motor activity using noninvasive NIR topography," *Med. Phys.* **22**, 1997-2005 (1995).
7. Y. Yamashita, A. Maki, Y. Ito, E. Watanabe, Y. Mayanagi, and H. Koizumi, "Noninvasive near-infrared topography of human brain activity using intensity modulation spectroscopy," *Opt. Eng.* **35**, 1046-1049 (1996).
8. P. W. McCormick, M. Stewart, G. Lewis, M. Dujovny, and J. I. Ausman, "Intracerebral penetration of infrared light," *J. Neurosurg.* **76**, 315-318 (1992).
9. N. C. Bruce, "Experimental study of the effect of absorbing and transmitting inclusions in highly scattering media," *Appl. Opt.* **33**, 6692-6698 (1994).
10. M. S. Patterson, B. Chance, and B. C. Wilson, "Time-resolved reflectance and transmittance for the noninvasive measurement of tissue optical properties," *Appl. Opt.* **28**, 2331-2336 (1989).
11. W.-F. Cheong, S. A. Prahl, and A. J. Welch, "A review of the optical properties of biological tissues," *IEEE J. Quantum Electron.* **26**, 2166-2185 (1990).
12. E. Watanabe, A. Maki, F. Kawaguchi, Y. Yamashita, H. Koizumi, and Y. Mayanagi, "Noninvasive cerebral blood volume measurement during seizures using multichannel near infrared spectroscopic topography," *J. Epilepsy* **11**, 335-340 (1998).