

International Conference on Space Optics—ICSO 1997

Toulouse, France

2–4 December 1997

Edited by George Otrio



A compact very high resolution camera (VHRC) for Earth and planetary exploration using a large array (7k x 8k) CCD

Hans-Georg Grothues, Frank Lehmann, Harald Michaelis, Gerhard Neukum, et al.



icso proceedings



International Conference on Space Optics — ICSO 1997, edited by Georges Otrio, Proc. of SPIE Vol. 10570, 105700D · © 1997 ESA and CNES · CCC code: 0277-786X/18/\$18 · doi: 10.1117/12.2326445

**A COMPACT VERY HIGH RESOLUTION CAMERA (VHRC)
FOR EARTH AND PLANETARY EXPLORATION
USING A LARGE ARRAY (7K X 8K) CCD**

**Hans-Georg GROTHUES, Frank LEHMANN, Harald MICHAELIS,
Gerhard NEUKUM, René PISCHEL, Einhard RESS**

DLR Institute of Planetary Exploration, Rudower Chaussee 5, D-12489 Berlin, Germany

ABSTRACT - A concept is presented of a compact and very light-weight camera system for Earth and planetary exploration realizing a panchromatic ground resolution of about 1 to 1.5 m per pixel from orbits of 500 to 800 km. Heart of the camera system is a new 7k x 8k Philips CCD (12 μ m pixels) which allows a large field of view at the given very high resolution. Using modern, properly tailored ceramic composite materials (C/C-SiC or C/SiC) for the primary and secondary, parts of the optical bench, and the mechanical structure, will - together with an extremely short optical design - limit the mass of the system (camera including CCD and detector electronics) to about 7 to 8 kg. Nevertheless, it may be an advantage to manufacture the whole opto-mechanical system (mirrors and optical bench) from Zerodur which will slightly increase the mass. The main fields of application of the camera will be commercial remote sensing, e.g. for regional planning, or mobile communication modeling, military verification tasks, and geological surface studies and preparation of lander and rover missions in planetary exploration.

1 - INTRODUCTION

Most of the existing space-borne operational camera systems for terrestrial remote sensing, e.g. Landsat and SPOT, are operated at ground resolutions of more than 10 m per pixel, and usually have masses in excess of 100 kg. Considerably higher ground resolutions (less than 1 to 10 m / pixel) have only been achieved by government and military reconnaissance satellites which are capable of obtaining resolutions as high as 0.3 to 0.4 m from low Earth orbits with highly sophisticated and very expensive systems like the United State's KH-11 spacecraft.

Only during the last few years commercial satellites have been built and launched (or are soon to be launched) which realize panchromatic ground resolutions of the order of 1 to 5 m / pixel. Examples are India's IRS-1C satellite (~5 m / pixel; launch Dec. 1995), EarlyBird of EarthWatch Inc. (~3 m / pixel; launch intended in late 1997), Ikonos 1 and 2 of Space Imaging Eosat (< 1 m / pixel; launch intended in Dec. 1997 and Sept. 1998 resp.), and OrbView-3 of Orbital Sciences Corp. (1 m / pixel; launch intended in 1999). Nearly all these satellites incorporate camera payloads of masses considerably larger than 100 kg. Imaging in these systems is mostly realized using the pushbroom principle with linear CCD arrays.

For planetary missions stringent mass constraints limit the sizes of the camera systems, and thus the achievable resolutions. At the Moon and Mars (Lunar Orbiters, Clementine, Viking Orbiter) the

resolutions were generally of the order of 100 m from orbits of a few 100 km. A much higher ground resolution of about 10 to 20 m / pixel should have been obtained at Mars with the DLR-HRSC (High Resolution Stereo Camera) flown on the failed Mars-96 mission.

In terrestrial remote sensing, high resolution of 1 m / pixel is a clear demand of the potential users as only these resolutions can ensure the appropriate imaging of details, especially if the requirements from modern high-precision navigation systems like GPS are taken into account. Applications are, for example, classification, regional planning, hazard-warning, and damage assessment in coastal areas, mobile communication modeling, and, possibly, also military verification tasks. For planetary exploration, applications of high resolution camera systems are the preparation and support of future lander and rover missions, especially on Moon and Mars, but also the study of surface details like strata, rocks, and "hazards".

Combining the need of very high ground resolutions in terrestrial remote sensing and planetary geology with the requirements of future small and dedicated ESA and NASA missions to planetary targets, the DLR Institute of Planetary Exploration has designed an extremely light-weight but nevertheless Very High Resolution Camera (VHRC) which will be capable of achieving a ground resolution of about 1 to 1.5 m / pixel from orbits of 500 to 800 km. Although the performance of the VHRC is very high, it will be small and light-weight enough to fit the stringent payload mass constraints of Earth orbiting micro-satellites (total mass < 100 kg). In addition to the high resolution, a large field of view is realized by using a 7k x 8k Philips large array CCD operated in TDI mode as the sensor of the system. The following sections outline the optical design (Sect. 2) and the optomechanics of the VHRC (Sect. 3), and describe the large array CCD (Sect. 4), and the shutter problem (Sect. 5). Finally, Sect. 6 will draw the most important conclusions. An overview of possible applications of high resolution remote sensing with the VHRC / large array CCD is also given by Neukum et al. (Neuk 97).

2 - CAMERA OPTICS

From the required very high resolution of the camera of nominally 1.0 m / pixel from an orbit of 500 km follows an angular resolution of 2.0 μ rad (0.4 arcsec) which translates to a clear aperture of approximately $D = 35$ cm if a diffraction-limited optics is considered (for visual wavelengths, $\lambda_0 = 0.55 \mu$ m). Adapting the camera to a CCD with square pixels of size p results in an f-number

$$f / D = 0.82 p / \lambda_0 \quad (2.1)$$

Inserting $p = 12 \mu$ m for the 7k x 8k Philips CCD (cf. Sect. 4) gives $f \approx 6.3$ m. Thus, we adopted $D = 0.35$ m and a focal length of $f = 6.0$ m as the baseline for the VHRC optical design (Tab. 1). Furthermore, a diameter of 130 mm was assumed for the focal plane (diagonal of the 7k x 8k Philips CCD with a photosensitive area of 86.0 x 98.3 mm²; this CCD will replace the experimental 7k x 9k version in the future; cf. Sect. 4).

The camera optics of the VHRC consists of a Ritchey-Chrétien-like system with hyperbolic primary and secondary mirrors, and a 4-lens field corrector designed of spherical surfaces only (Fig. 1). Besides its main task to flatten the focal surface, the field corrector also has the important purpose to prolong the system's focal length to gain the demanded value of 6 m. With only 1.43, the f-number of the reflector system is extremely low, requiring in particular a very careful manufacturing and testing of the primary, comparable to the most sophisticated optical systems for astronomical purposes that have already realized. The goal of the extreme curvatures of the primary and secondary was to achieve the shortest possible length of the camera system: with only 63 cm between the apex of the secondary and the focal plane, the system length is just about 10 % of its focal length. Thus, the

VHRC is one of the most compact optical systems ever designed. The main parameters of the optics are summarized in Table 1.

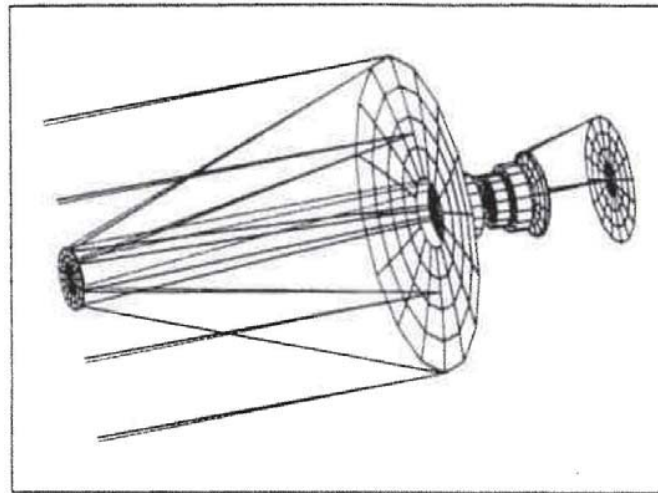

Fig. 1: Optical design of the VHRC with secondary, primary, field corrector, and focal plane (from left to right)

Table 1: Parameters of the VHRC optics

Optics	catadioptric system with aspheric reflector and field corrector, diffraction-limited
Aperture	0.35 m
Focal length	6.00 m
f-number	17.1
Wavelength range (chromatic correction)	0.4 - 0.8 μm
Focal plane diameter	130 mm
FOV (diameter)	1.24 degrees (10.8 km from 500 km orbit)
IFOV (12 μm pixels)	0.4 arcsec (1.0 m / pixel for 500 km orbit)

Figure 2 demonstrates the very good (theoretical) performance of the VHRC optics. The MTF at the Nyquist limit of 41.7 cycles per mm for the 12 μm CCD pixels stays above ~30 % over the whole FOV. The small remaining image defects are illustrated by the spot diagrams and compares them to the Airy disk. The calculated peak-to-valley wavefront aberrations remain below $\lambda/10$ over more than 80 % of the field radius, increasing to about $\lambda/6.5$ at the very edge of the field. This leaves enough margin for manufacturing tolerances to be compensated in a careful production of the optics without losing the diffraction-limited performance.

3 - OPTO-MECHANICAL DESIGN AND MATERIALS

A first opto-mechanical design of the VHRC based on a mixed approach of conservative materials and new ceramic compounds is shown in Figure 3. The hexapod used to mount the secondary ensures that this mirror is connected to the primary in such a way that the total degree of freedom of the system results to zero, and that simultaneously no torques and other moments of forces are induced to the structure. The uniqueness of the hexapod mounting was proven by Chebychev in 1868.

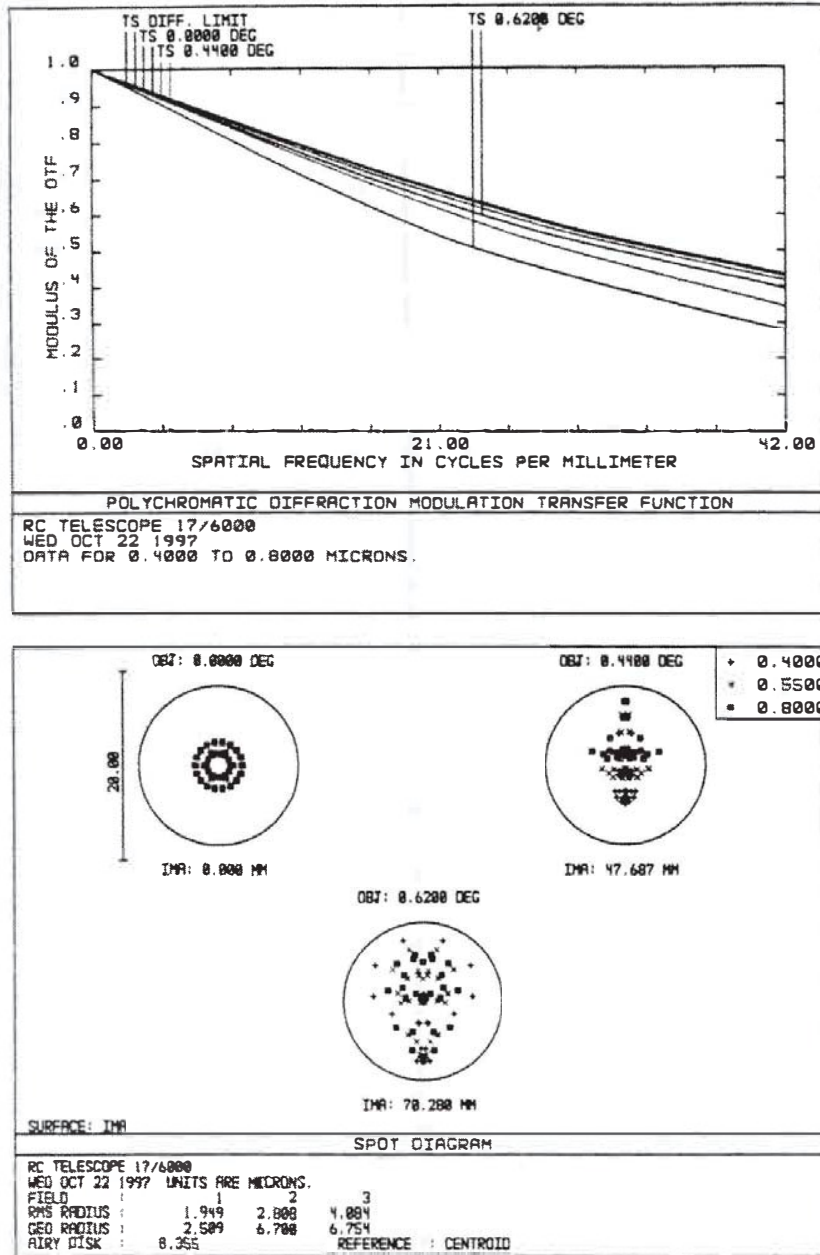

Fig. 2: Theoretical MTF (top) and spot diagrams (bottom) for the VHRC optics.
The Airy disk for $\lambda = 0.5 \mu\text{m}$ is indicated by the circles

The primary and secondary will either be manufactured from Zerodur, or from the ceramic carbon compound material C/C-SiC (or C/SiC) which has the advantage of a low thermal expansion over a wide range of temperatures at a similar or lower density than Zerodur, and a much better thermal conductivity. More information about the material is given below. The primary is supported at three points with no further mounting to save some mass. Below the main mirror a hexagonal tube contains the field corrector, the focal plane assembly (CCD and near-sensor electronics), and the shutter mechanism. Because the first lens of the field corrector is projected into the bore of the primary the

fixation of the corrector and the mirror can be kept near each other. Thus, the mounting of the lens system is not a critical one when considering thermal shifts, even if the mounting of the lenses is made from a material with a CTE considerably larger than Zerodur, e.g. from Titan (CTE $\sim 9 \cdot 10^{-6} \text{ K}^{-1}$). Light-weight segmented baffles around the primary bore and the secondary serve to prevent stray light on the detector. The final construction of the baffles depends on the surrounding satellite structure and the incident light distribution.

A comprehensive analysis of the permissible tolerances for all optical elements leads to the following important results:

- (1) Manufacture and testing of the hyperbolic primary (conic constant = -1.0310 ± 0.0003) is very demanding but does not exceed current technical capabilities. The secondary is easier to handle. If made from C/SiC the internal tensions and long-term variations of the material have to be thoroughly investigated in order to avoid a secular degrading of imaging performance of the sensitive primary. The static parameters of the optics such as distances, decentering, and tilt show tolerances not unusual for any sophisticated optics.
- (2) In order to maintain the diffraction-limited imaging over a wide temperature range it is necessary to provide a focusing mechanism to automatically adjust the CCD detector (range approx. $\pm 2 \text{ mm}$). Even with the focusing the permissible distance tolerance between the primary and the secondary is only $\pm 4 \mu\text{m}$ which should nevertheless be treatable with some effort. The only way to possibly avoid a focusing mechanism is to construct the mirrors, hexapod, and the mounting of the field corrector completely from Zerodur, as has been demonstrated by Zeiss with the Silex telescope assembly.
- (3) Single-sided incidence of radiation has to be avoided for a C/SiC construction of the mirrors and hexapod (or constructions using conventional materials with CTEs $> 1 \cdot 10^{-6} \text{ K}^{-1}$). This requires a very careful thermal insulation of the whole camera.

Table 2 compares the typical properties of the carbon compound materials C/C-SiC and C/SiC with Zerodur and Invar-36. Carbon compound materials are considered for the VHRC to replace more conventional materials like Zerodur as the carrier for the high-precision camera mirrors and other optical components like the mounting of the field corrector, or as a light-weight material for the focal plate carrying the large array detector (instead of Invar; cf. Sect. 4). C/C-SiC has originally been developed and extensively tested as a high temperature material, e.g. for jet engines and other applications, by the DLR Institute of Structures and Design in Stuttgart, Germany (e.g. Kren 95, Hald 95). Similar materials (C/SiC, SiC) have been designed by a number of other institutions and companies in Europe and the USA.

The applicability of Carbon Silicate compounds (C/SiC) for carrying and polishing optical surfaces has been demonstrated successfully by the German company IABG (e.g. Deye 94) with the manufacture of a backup scanning mirror for the METEOSAT Second Generation satellite. The main advantages of C/SiC over Zerodur in optical applications are its higher (tunable) stiffness (modulus of elasticity) and flexural strength, and the much better thermal conductivity (Tab. 2).

Based on the opto-mechanical design described above a total mass of the VHRC including the camera optics with all mountings, the shutter mechanism, and the large array CCD with the near-sensor electronics (cf. Sect. 4) was estimated to amount to about 7 to 8 kg. This includes the primary, secondary, and hexapod manufactured from C/SiC (density $\sim 2.4 \text{ g cm}^{-3}$), the primary contributing about 2.2 kg to the total mass of the camera system. The mounting of the field corrector which is assumed to be constructed from Aluminum and Titan in the present version of the VHRC could provide the opportunity to further reduce the mass if it turns out that C/SiC is suitable for being used for that purpose. The mass frame of 7 to 8 kg given above may be exceeded by as much

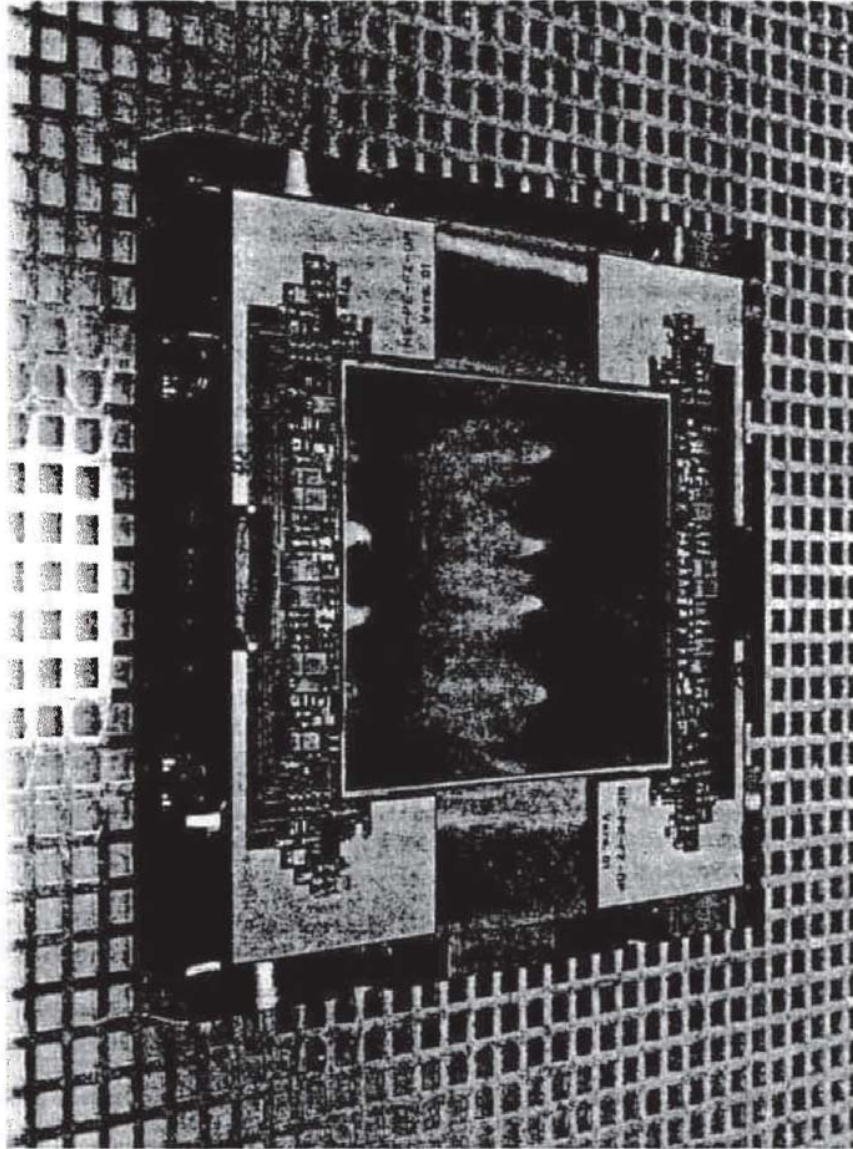

as 1 kg if a focusing mechanism for the focal plane (CCD) has to be taken into account (cf. discussion of tolerances above).

Table 2: Comparison of physical properties for C/C-SiC (C/SiC), Zerodur, and Invar-36 (20°C)

Material	C/C-SiC (C/SiC) ¹	Zerodur	Invar-36 ²
Density (g cm ⁻³)	1.9 - 2.6	2.53	8.0
Modulus of elasticity / tension (GPa)	90 - 240 ³	90	140 - 150
CTE (10 ⁻⁶ K ⁻¹)	1 - 2 ⁴ 4 - 6 ⁵	-0.02	1.2 - 2.0
Thermal conductivity (W m ⁻¹ K ⁻¹)	13 - 135 ³	1.46	12.8

¹ lower values refer to C/C-SiC, higher ones to C/SiC

² 64 % Fe, 36 % Ni

³ depending on structure of carbon fibers and processing

⁴ parallel to carbon fibers

⁵ perpendicular to carbon fibers

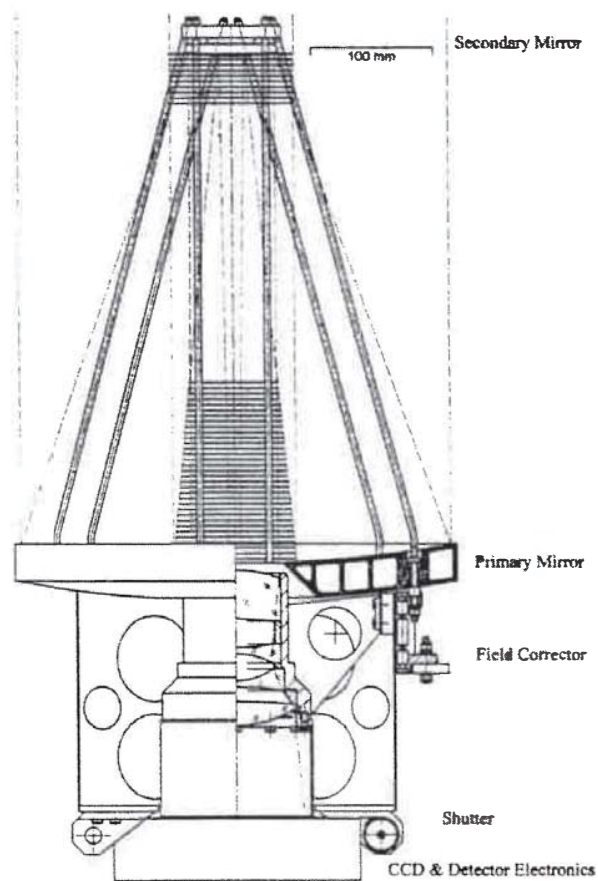

Fig. 3: Opto-mechanical structure of the VHRC

4 - LARGE ARRAY CCD

The new 150 mm (6") full wafer silicon CCD detectors which are intended to be used with the VHRC were developed by Philips Imaging Technology. The monolithic devices are produced using Philip's mK x nK modular CCD process which places 1k x 1k building blocks of pixels together to manufacture larger-format arrays (Phil 95). The Steward Observatory CCD Laboratory (University of Arizona, Tucson) and the DLR Institute of Planetary Exploration Sensor Electronics Group (Berlin) are extensively testing and characterizing several 7k x 9k experimental CCDs that have been manufactured using this technique (cf. Sect. 2 for a remark on the 7k x 8k version of the CCDs).

The first results of these investigations including the modular sensor electronics and the special packaging technique have been published in some detail by Lesser et al. (Less 97) and Behnke et al. (Behn 97). The most important parameters of the CCDs are summarized in Table 3. Figure 4 shows a complete packaging with near-sensor electronics as operated at DLR.

Table 3: Parameters of the Philips 7k x 8k CCDs (in brackets: 7k x 9k version)

Architecture	front-illuminated full frame CCD
Number of pixels	7168 x 8192 (7168 x 9216)
Pitch (pixel size)	12 μm (square)
Size of photosensitive area	86.0 x 98.3 mm^2 (86.0 x 110.6 mm^2)
Optical filling factor	100 %
Max. quantum efficiency (DQE)	-30 % (at ~550 nm)
Max. read-out frequency (4 channels)	4 x 10 Mhz (total read-out time ~1.5 s)
Total read-out noise (25°C)	-80 e (read-out frequency 4 x 2.5 MHz)
Full well capacity	> 100 ke

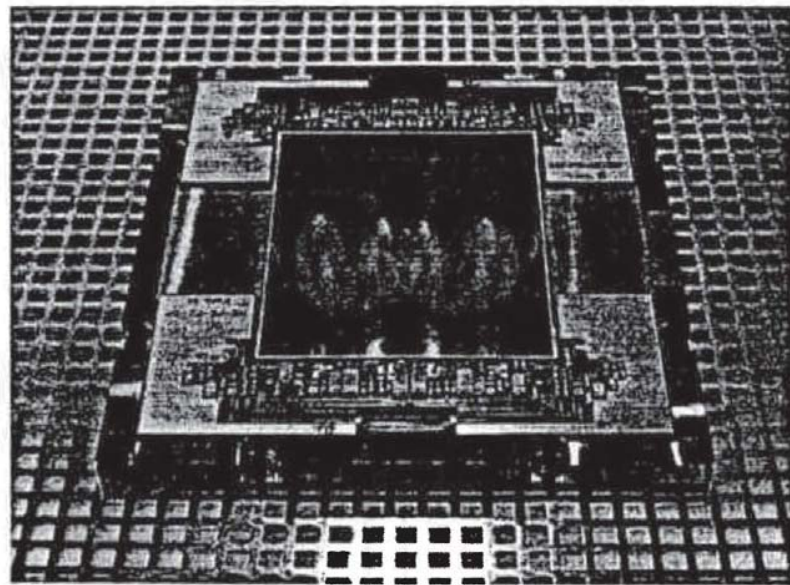

Fig. 4: Philips large array (7k x 9k) CCD packaging with near-sensor electronics. The photosensitive area measures about 86 x 111 mm^2

The operation of a large array (7k x 9k or similar) CCD with the VHRC will unite the contradictory requirements of very high pixel resolution with a simultaneously large FOV. In principle, this goal can also be achieved by using long linear CCD arrays. However, these arrays have the disadvantage of not having a fixed geometry between the consecutive rows of the image, and thus demanding a very high pointing accuracy of the whole camera (satellite), if resolutions of the order of 1 m / pixel are envisaged: the maximum drift of the pointing should be $-0.2 \mu\text{rad} / \text{s}$ if deviations of 10 % are permitted over a whole image of about 7200 rows, and a consequent scanning time of $\sim 1.0 \text{ s}$ (500 km Earth orbit). Such a pointing accuracy is very difficult if not impossible to achieve for simple and low-mass attitude control devices implemented on small micro-satellites. It must, however, be admitted that a certain geometric correction is possible when processing the image data. Furthermore, the exposure times with linear arrays are restricted to the time interval needed for the image to drift about one pixel on the detector ($\sim 0.13 \text{ ms}$ for a 500 km Earth orbit) which may cause problems with the SNR in the image ($f / 17.1$!). On the other hand, despite the advantages of 2D-arrays for high resolution imaging, the shutter problem has not been completely solved for large array CCDs yet (cf. Sect. 5).

To be able to realize arbitrary exposure times with large arrays at the VHRC on a moving satellite without losing spatial resolution by smearing several pixels, the CCD has to be operated in TDI (time delay integration) mode. This is to read out the CCD during the exposure at a speed that compensates the image drift with respect to the detector. For a typical drift speed of 90 mm / s in the VHRC focal plane on a 500-km orbit, an exposure time of 2.13 ms can be reached with 16 TDI steps. The maximum number of steps possible with the 7k x 8k CCDs has still to be investigated. Exposure times up to about 12 ms (64 TDI steps) shall be realized.

A special feature of the 7k x 8k CCDs regarding their application with the light-weight VHRC is the baseplate on which the CCD packaging is mounted. The usual Invar-36 plate which has been used during the tests weighs about 3 kg and has not been optimized for low mass. In order to fulfill the stringent mass requirements of the VHRC but to maintain the favorable mechanical properties of Invar (stiffness, thermal expansion and conduction), a baseplate made from C/C-SiC (cf. Sect. 3) has been manufactured with a mass of now only about 700 g. Presently, a CCD is mounted on this plate, and will be tested in the near future. Usually, the CTE of C/C-SiC is 2 to 6 times larger if measured perpendicular to the carbon fibers than parallel to them (Tab. 2). In the case of the VHRC this causes no problems with the focus, as the depth-of-focus of the camera is nearly 300 μm (large f-number).

5 - SHUTTER

As mentioned above (Sect. 4) the exposure control of large CCDs with dimensions $> 100 \text{ mm}$ is a problem when exposure times less than 30 to 50 ms are required. Most of the electro-mechanical shutter principles (e.g. iris diaphragms, rotational shutters, or scanners) are not suitable to solve this problem. They are either too slow (or the maximum aperture too small if exposure times of a few ms are reached), or have dimensions and masses too large to meet the requirements of the VHRC.

Two different approaches are followed by DLR to overcome the exposure control problem:

- (1) A light-weight high-speed slit shutter scans the image by moving across the CCD directly above the focal plane at a speed depending on the effective exposure time. The shutter mechanics has to be damped carefully to avoid inducing vibrations into the camera (or satellite) structure, caused by the accelerations and decelerations of the slit unit. Minor image distortions caused by the shutter can easily be corrected by subsequent image processing.

- (2) A large array liquid-crystal (LC) shutter based on ferroelectric LCs is capable of attenuating incident light by a factor of approximately 200 : 1 over the wide wavelength range from 0.4 to 0.8 μm (possible exposure times < 1 ms). This means that a 0.5 %-level exposure continues even if the shutter is "closed", causing an additional background over the image to be generated. This background can be removed by suitable image processing as long as it does not exceed the full well capacity of the CCD. The disadvantage of an LC-shutter is that it acts as a polarizer, thus transmitting only about 40 % of the incident radiation.

Despite some problems to be solved regarding the large-array high-speed shutter, DLR is quite optimistic to overcome the remaining obstacles when realizing the VHRC camera system.

6 - CONCLUSIONS

The most important results of the VHRC and large array CCD study can be summarized as follows:

- (1) The optics design study and tolerance analysis, and the first order opto-mechanical design has shown that a space camera with a very high (panchromatic) ground resolution of the order of 1 m / pixel can be realized by a compact and light-weight system capable of being integrated into a micro-satellite. A volume of about 40 cm in diameter and 80 cm in length seems to be sufficient to house the camera. The resulting mass will be around 7 to 8 kg (< 10 kg if conventional materials are used). The challenge now is to translate the design into a functioning prototype.
- (2) Large array CCDs are best suited to meet the contradictory requirements of the VHRC of very high resolution and a large swath or FOV. DLR continues to characterize the Philips 7k x 8k CCDs in order to prepare them for space applications. A huge challenge for data storage, data compression, and telemetry will be the enormous data volumes produced by the VHRC. Typically, the uncompressed raw data of one image taken with full resolution will amount to roughly 700 Mbits (!) at 12 bits per pixel radiometric resolution.
- (3) Still not completely solved is the task of controlling short exposure times with large array CCDs. Possible solutions are a scanning high-speed slit-shutter, or a liquid-crystal array.
- (4) The VHRC will open new applications in terrestrial (commercial) remote sensing and planetary exploration at comparably low cost because of its low mass substantially reducing the cost for a launch of dedicated satellites and spacecraft. Examples are mobile communication propagation modeling on Earth, and the preparation and support of lander and rover missions to the Moon and Mars.

7 - ACKNOWLEDGEMENTS

We are indebted to Albert Theuwissen (Philips), James Foster (ADI), Burkhard Zellner (Vision 2000), and Mike Lesser (University of Arizona / Steward Observatory) for their assistance in providing the large array CCDs, and their advice and information concerning the operation. Furthermore, we have to thank Thomas Behnke and Mathias Tschentscher who carried out most of the measurements with the CCDs, and Helmut Hirsch for providing Figures 1 and 2. Finally, Manfred Steinbach and his colleagues of the Optikzentrum NRW (Bochum) have to be mentioned for many fruitful discussions on the optical design, the opto-mechanics, and the solution of the shutter problem.

REFERENCES:

- [Behn 97] Th. Behnke, H.-G. Grothues, E. Koldewey, H. Michaelis, E. Röss, M. Tschentscher : "Philips 7k x 9k Large Array - Status Report", *Publication of the DLR Institute of Planetary Exploration*, DLR, Berlin, May 1997

- [Deyerle 94] M. Deyerler, B. Kunkel, B. Harnisch, A. Pradier, U. Papenburg : "C/SiC - an Ultra-lightweight Structural Material for Optical Components and further Applications", *Proceedings of the International Symposium on Advanced Materials for Lightweight Structures '94*, ESA-ESTEC, Noordwijk, March 1994, pp. 63 - 67
- [Hald 95] H. Hald, P. Winkelmann : "TPS Development by Ground and Reentry Flight testing of CMC Materials and Structures", *2nd European Workshop on Thermal Protection Systems*, ESA, Stuttgart, October 1995
- [Kren 95] W. Krenkel, J. Fabig : "Tailoring of Microstructure in C/C-SiC Composites", *Proceedings of ICCM-10*, Whistler, B.C., Canada, August 1995
- [Lesser 97] M. Lesser, D. Ouelette, A. J. P. Theuwissen, G. L. Kreider, H. Michaelis : "Packaging and Operation of Philips 7k x 9k CCDs", *Workshop Proceedings of the 1997 IEEE Workshop on Charge-Coupled Devices & Advanced Image Sensors*, Bruges, June 1997, pp. R-33, 1 - 4, Bruges, June 1997
- [Neukum 97] G. Neukum, H.-G. Grothues, F. Lehmann, H. Michaelis, R. Pischel : "Application of Large-Array CCD-Sensors for Terrestrial and Planetary Remote Sensing: Development of a Compact and Very High Resolution Camera (VHRC)", *Publication of the DLR Institute of Planetary Exploration*, DLR, Berlin, January 1997
- [Philips 95] Philips : "The mK x nK Modular Image Sensor, a Modular CCD", *Philips Imaging Technology*, 1995

Contacts: H.-G. Grothues (e-mail: hg.grothues@dlr.de)